

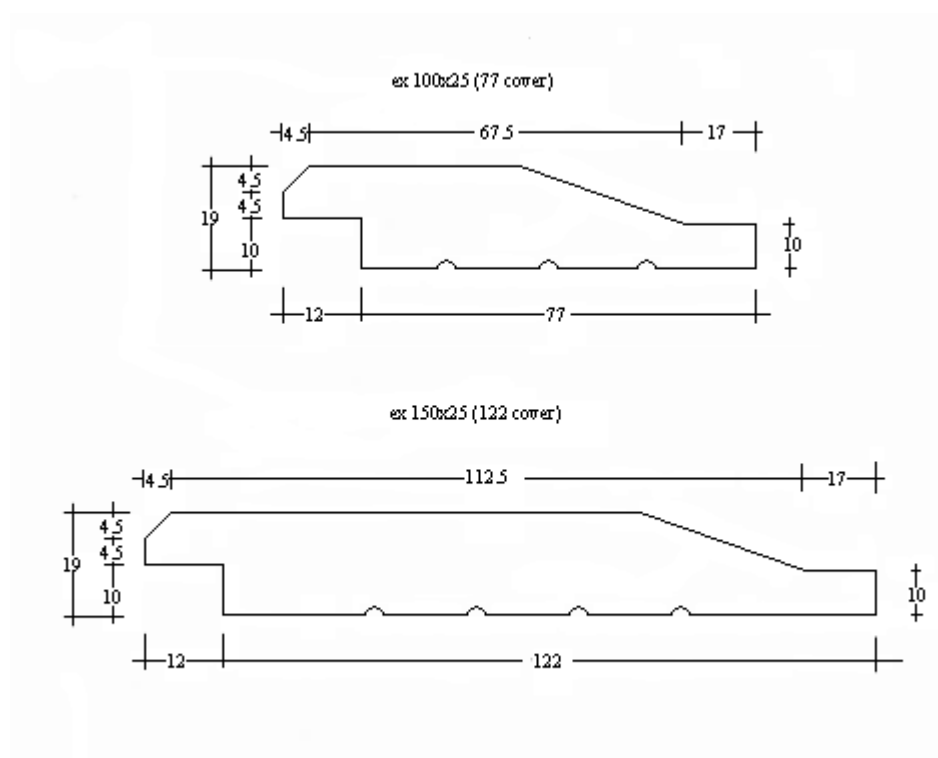

CHAMFER



TOLERANCES:

At the time of machining, the tolerances on any dimension in the width and thickness of the piece shall be + or - 0.5mm.



SHIPLAP

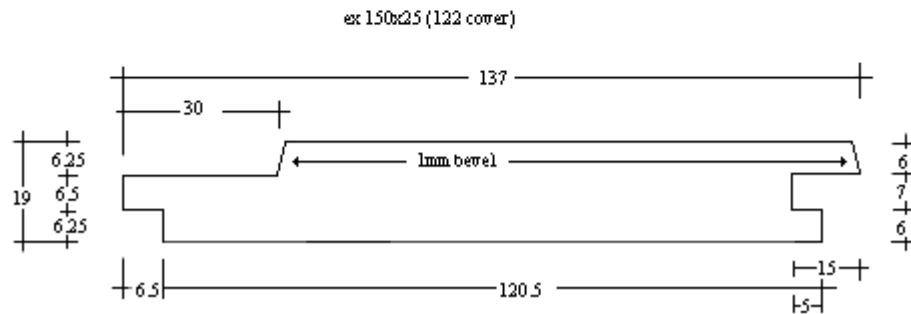
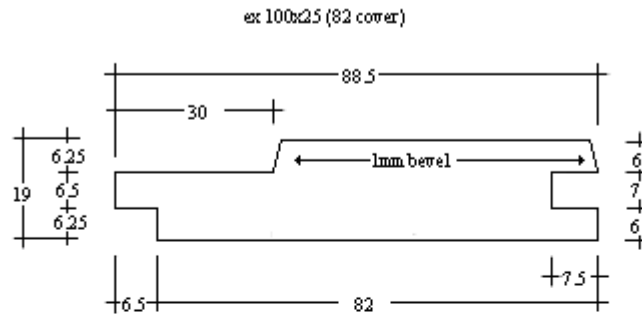

TOLERANCES:

At the time of machining, the tolerances on any dimension in the width and thickness of the piece shall be + or - 0.5mm, provided that the clearance between tongues and grooves is not more than 1mm nor less than 0.25mm and any mismatch does not exceed 0.5mm



T&G

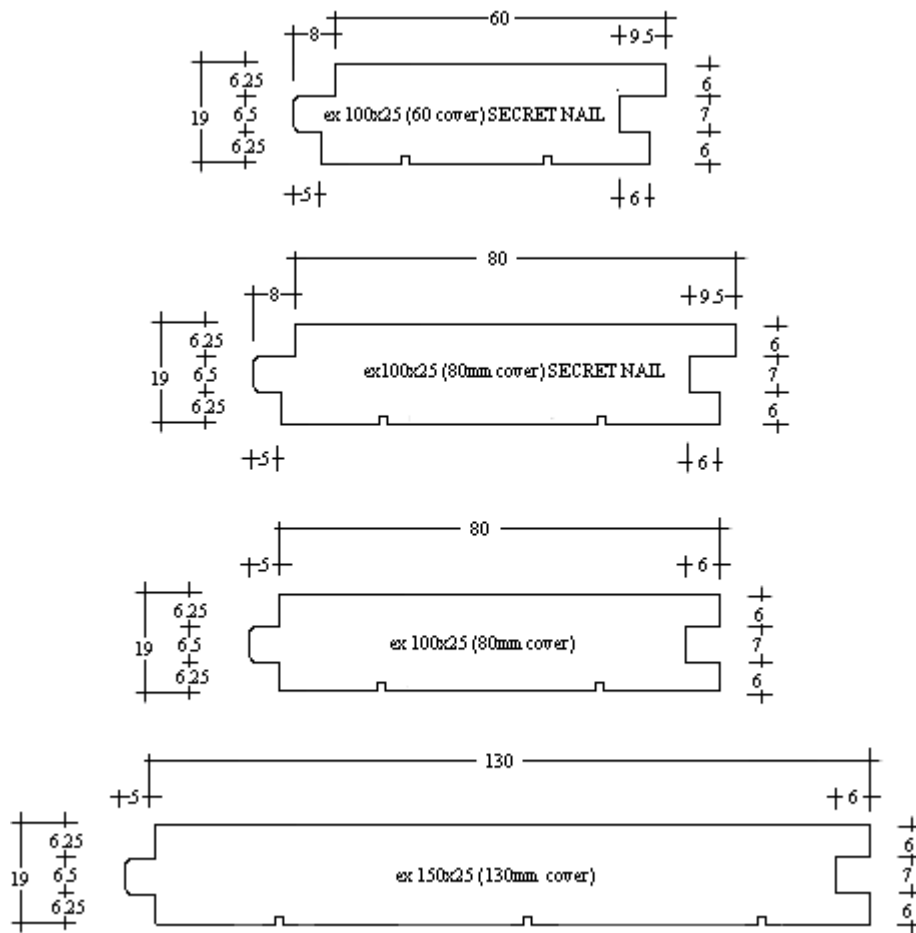

TOLERANCES:

Overall thickness, + or - 0.5mm

Dimensions in thickness other than overall thickness, + or - 0.3mm

Any mismatch does not exceed 0.5mm

Tongue and groove clearance is not more than 0.6mm and less than 0.3mm

Dimensions in width including cover width + or - 0.3mm



CYPRESS T&G

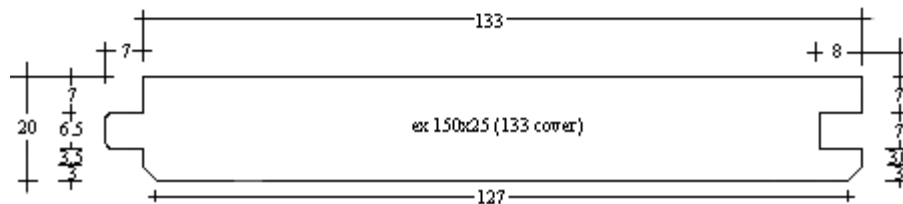
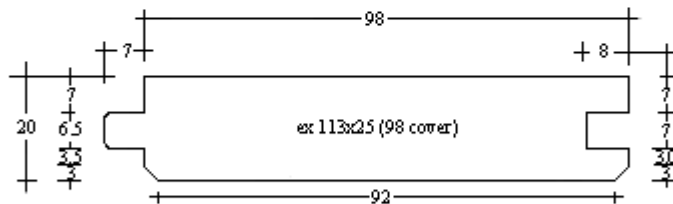
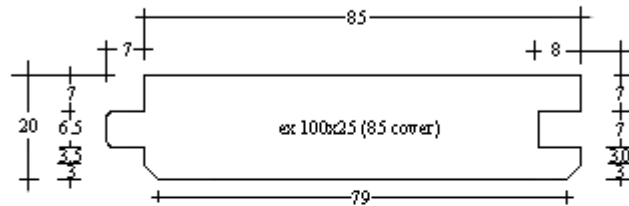
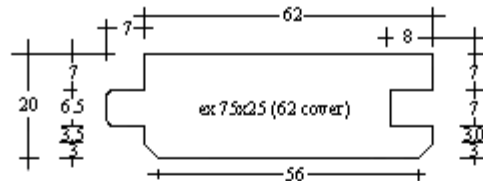

TOLERANCES:

Overall thickness, + or - 0.5mm

Dimensions in thickness other than overall thickness, + or - 0.3mm

Any mismatch does not exceed 0.5mm

Tongue and groove clearance is not more than 0.6mm and less than 0.3mm

Dimensions in width including cover width + or - 0.3mm



DECKING

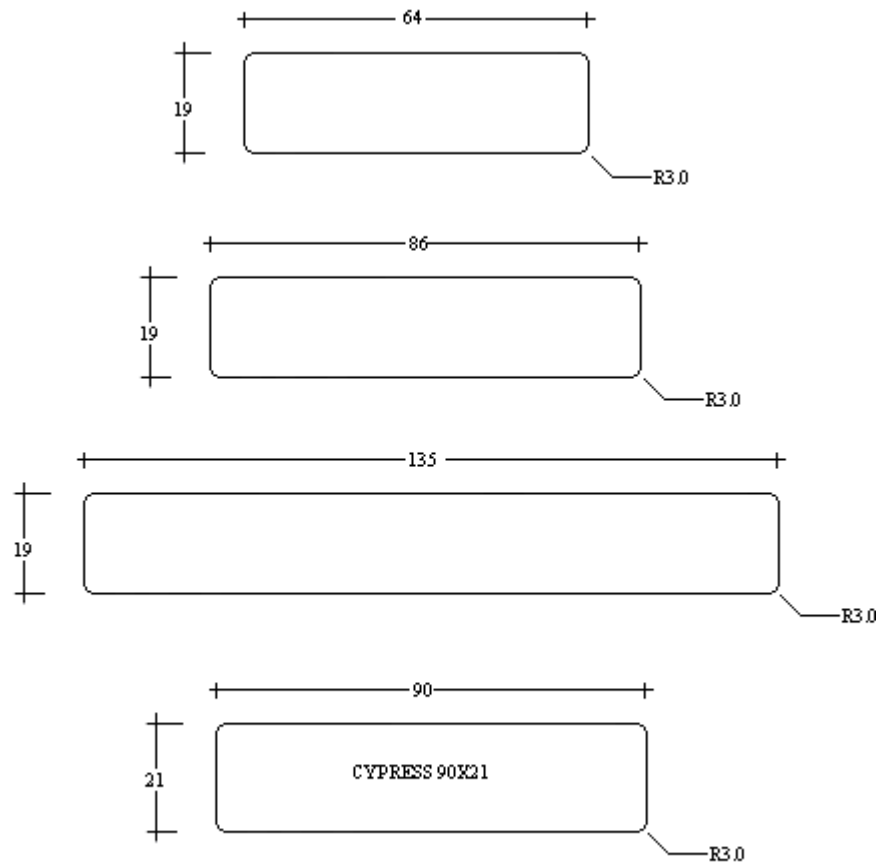

TOLERANCES:

At the time of machining, the tolerances on any dimension in the width and thickness of the piece shall be + or - 0.5mm.